

01-07-2025

**NRGC Committee Meeting
Supplemental Packet**

Outdoor Lighting Ordinance (From the Town of Taos NM)

The purpose of this chapter is to regulate outdoor lighting in order to reduce or prevent light pollution. This means, to the extent reasonably possible, the reduction or prevention of glare and light trespass, the conservation of energy, and the promotion of safety and security. This chapter will ensure the aesthetically appropriate outdoor lighting in keeping with the historic character and night sky beauty of the town. (Ordinance 07-02 adopted 2007)

§ 15.28.020 **Definitions.**

As used in this section [this chapter]:

Accent lighting.

Any directional lighting which emphasizes a particular object or draws attention to a particular area.

Disabling glare.

Lighting that impairs visibility and creates a potentially hazardous situation for either pedestrians or motorists.

Glare.

The brightness of a light source that causes eye discomfort.

Lamp or bulb.

The light producing source installed in the socket portion of a luminaire. Types of bulbs that comply with this chapter and their relative efficiencies are listed in section **15.28.110** of this chapter.

Light pollution.

General night sky glow caused by the scattering of artificial light in the atmosphere resulting in decreased ability to see the natural night sky.

Light trespass.

Light emitted by a luminaire that shines beyond the property on which the luminaire is installed.

Lumen.

A unit of light or illumination from a lamp or bulb.

Luminaire or fixture.

A complete lighting unit including the lamps or bulbs, together with the parts required to distribute the light, to position and protect the lamps, and to connect the lamps to the power supply. "Wall packs" and "porch lights" are two (2) terms used to describe outdoor fixtures mounted on building structures. Terms used by the industry to identify fixtures that comply with this chapter are:

A.

"Full cutoff".

B.

"Night sky or dark sky friendly (or compliant)".

C.

"International Dark Skies Association approved (IDA approved)".

D.

"Ordinance compliant".

Nuisance glare.

Light that creates an annoyance or aggravation but does not create a potentially hazardous situation.

Shielding.

No light rays emitted by a fixture above the horizontal plane running through the lowest point of the fixture where light is emitted.

Spotlight or floodlight.

Any lamp that incorporates a reflector or a refractor to concentrate the light output into a directed beam in a particular direction.

Watt.

A unit of electric power flowing into a lamp or bulb.
(Ordinance 07-02 adopted 2007)

§ 15.28.030 **Applicability.**

A.

All nonconforming outdoor fixtures installed prior to and operable on the effective date hereof shall be removed or converted to a conforming use within seven (7) years. The town may require a nonconforming use to be corrected within the seven (7) year grace period if the town determines that the nonconforming use is a continuing violation of any provision of this chapter.

All existing outdoor lighting fixtures owned and maintained by Kit Carson Electric Cooperative before the effective date hereof are exempt from the requirements of subsection **A** of this section. When the existing Kit Carson Electric Cooperative fixtures become inoperable or unrepairable, their replacements are subject to all the provisions of this chapter and the state Night Sky Protection Act, as may be amended.

B.

This chapter does not apply to interior lighting. However, overly bright interior light emitted outdoors from any structure will be subject to control by this chapter if it is determined by the code administrator that it creates a “nuisance glare” or “disabling glare” as defined by this chapter.

C.

New installations and modifications to exiting [existing] nonconforming fixtures in the designated town historic district shall comply with this chapter.

D.

Compliance with this chapter shall be administered and enforced by the town planning department.

E.

All governmental agencies, federal, state or county, including their security facilities which operate within the town limits, must follow the provisions of this chapter. The state construction industries division of the regulation and licensing department shall review the state's outdoor lighting provisions in the building codes used in New Mexico and the town and make recommendations for appropriate changes to comply with the provisions of the state Night Sky Protection Act and the town night skies protection ordinance and shall permit and inspect (to the standards set forth in these night sky protection acts) all construction of and on state owned buildings that is subject to permit and inspection under the state Construction Industries Licensing Act. The construction industries division (CID) of the State of New Mexico is responsible for the enforcement of the state Night Sky Protection Act. For guidance they can be contacted at 505-476-4700.

F.

In the event of a conflict with any other section of this chapter, the more stringent requirement shall apply.
(Ordinance 07-02 adopted 2007)

§ 15.28.040 **Exemptions.**

The following are exempt from the provisions of this chapter:

A.

Traffic control signals and devices.

B.

Streetlights installed prior to the effective date of the original ordinance.

C.

Temporary emergency lighting (i.e., fire, police, repair workers).

D.

Moving vehicle lights.

E.

Navigation lights (i.e., airports, heliports, radio/television towers).

F.

Seasonal decorations with light displays in place no longer than November 15 to April 1.

G.

Sports field outdoor lighting sites existing at the date of passage of the original ordinance (i.e., ball fields, ice rinks, etc.). Any new town sports lighting installations (or any overall, complete replacement) shall be compliant without diminishing adequate illumination and safety.

H.

Other special situations approved by the town for temporary or periodic events (i.e., rodeos, revivals, fairs, fiestas,

carnivals, emergency or town sanctioned nighttime construction).

I.

Covered porch lighting on single-family or multi-family homes provided that each outdoor light fixture does not exceed 2200± lumens output (150 watts incandescent). Section **15.28.110**, table 5, of this chapter shows conversion of watts (power input) to lumens (light output) for the other allowed types of light sources.

J.

Security lights of any power that are controlled by a motion sensor switch and which do not remain on longer than twelve (12) minutes after activation.

K.

Any person or business may submit an application for an administrative exemption from the requirements of this chapter to the town planning department, planning director. The request shall state fully:

1.

The circumstances and conditions relied upon as grounds for administrative exemptions;

2.

The circumstances and conditions by which strict application of the provisions of this chapter would result in a financial hardship or deprive the applicant of reasonable use of the land, building or outdoor light fixtures; and

3.

The grounds by which the granting of the administrative exemption will not be injurious to the neighborhood or otherwise detrimental to the public health, safety or welfare. (Ordinance 07-02 adopted 2007)

§ 15.28.050 **Submittals.**

A.

Applications for building permits shall be submitted to the town planning department and, if applicable, the historic preservation commission. If they include installation of outdoor lighting fixtures they shall provide evidence of compliance with the requirements of this chapter. The application shall contain the following information and be submitted as part of the site plan to the planning department for approval:

1.

Plans indicating the location, type, and height of luminaires including both building and ground mounted fixtures;

2.

A description of luminaires, including lamps, poles or other supports and shielding devices, provided as catalog illustrations from the manufacturer;

3.

Ganging of individual luminaires to achieve more than allowed lumens in a specific area is prohibited. They may be ganged on a single standard only if focused downward on different areas;

4.

Photometric data, such as that furnished by the manufacturer, showing the downward angle of light emission;

5.

The governmental authority responsible for the oversight of the proposed building activity must be established in writing, be it the Town of Taos, County of Taos, State of New Mexico or federal government;

6.

Additional information may be required by the planning department in order to determine compliance with this chapter.

To help assure compliance with this chapter the following certification shall be executed on submittals to the town planning department for all commercial and multi-family projects:

Engineer's, Architect's or Licensed Contractor's Certification, Date
I, _____, a Registered Professional Engineer, Architect or Licensed Contractor, number _____ under the Laws of The State of New Mexico, hereby certify that the Outdoor Lighting Plan on this drawing was prepared under my direction and conforms to the Town of Taos Lighting Ordinance 07-02 Chapter 15.28 and is true and correct to the best of my knowledge and belief.
Signed by Registered Professional Engineer, Architect, or Individual Home Builder.

B.

Requests for any lighting deviation from the requirements of this chapter are to be submitted in writing to the town of Taos planning department. It shall be approved only when it is determined that a deviation is warranted in order to provide even more security for personal property, business inventory, agricultural activities.

1.

The lighting deviation application shall contain a detailed site plan showing the location and type of lighting fixtures

and the lumens/wattage deviations for each fixture sought by the applicant. In addition, the site plan shall show the locations of all buildings, public streets and roadways and other structures located within two hundred feet (200') of the property.

2.

The requested deviation shall be reviewed by the planning director. The planning director may grant the application, with or without conditions, if the director determines that the general standards of this chapter are met. Determinations of the planning director may be appealed by the applicant to the planning commission by written notice of appeal filed with the planning director within ten (10) calendar days following written notification to the applicant of the director's determination. Appeals from determinations of the planning commission shall follow the appeal procedure of the town's zoning ordinance as amended from time to time.

3.

No certificate of occupancy will be granted until all provisions of subsection **A** of this section and this subsection **B** are satisfied.

C.

Unlicensed individuals building or remodeling their personal property must also comply with subsections **A** and **B** of this section.

(Ordinance 07-02 adopted 2007)

§ 15.28.060 **General standards.**

The following general standards shall apply to all outdoor lighting installed after the effective date of the original ordinance which are not covered under exemptions:

A.

Outdoor lighting must be hooded, shielded and aimed downward. Examples of acceptable and unacceptable light shielding and hooding are shown in section **15.28.110**, figures 1 through 4 of this chapter.

B.

The hood or shield must mask the direct horizontal surface of the light source. The light must be aimed to ensure the illumination is only pointing downward onto the ground surface, with no upward escaping light permitted to contribute to sky glow.

C.

Any bright light shining onto adjacent property or streets which results in nuisance glare or disabling glare shall not be permitted. Light trespass beyond property boundaries or above the horizontal plane shall be considered noncompliant.

D.

Existing fixtures may be adapted to comply with this chapter by adding a properly designed hood or shield, or by pointing any upward mounted, shielded fixture downward toward the ground surface.

E.

All outdoor lighting fixtures shall be designed, installed, located and maintained such that glare onto adjacent properties or streets shall be minimized and all direct

illumination kept within the boundaries of the fixture owner's property.

F.

Accent lighting, when so approved, shall be directed downward onto the building or object and not toward the sky or onto adjacent properties. Direct light emissions shall not be visible above the roofline or beyond the building edge.

G.

Spotlighting on landscaping and foliage shall be limited to 2200± lumens output (150 watts incandescent). The lamp shall be shielded and not create disabling or nuisance glare.

H.

This section shall be enforced on the basis of a formal complaint filed in writing with the planning department.
(Ordinance 07-02 adopted 2007)

§ 15.28.070 Further restrictions.

The town reserves the right to further restrict outdoor lighting, including, but not limited to, searchlights for special events, quartz lighting, laser lights, pole height, and level of illumination, when it is deemed to be in the best public interest and in keeping with the stated purpose of this chapter.

(Ordinance 07-02 adopted 2007)

§ 15.28.080 Enforcement and penalties for violation.

This chapter shall be enforced when a town code enforcement officer determines a violation has occurred or when any citizen complains in writing to the town manager or planning director and the complaint is determined to be legitimate within the spirit of this chapter. The town code

enforcement officer will contact the owner, tenant, agent, or person in charge of any premises or any other person who violates any of the provisions of this chapter.

A.

For the first offense, the offender may be issued a warning with thirty (30) days to correct the offense.

B.

Penalties for commercial and nonresidential lighting violations. Any further violations of the provisions of this chapter shall constitute a petty misdemeanor, and upon conviction thereof, shall be punishable by a fine not to exceed one hundred dollars (\$100.00) for the first violation; three hundred dollars (\$300.00) for the second violation; and five hundred dollars (\$500.00) for the third violation.

C.

Penalties for residential violations. Any further violations of the provisions of this chapter shall constitute a petty misdemeanor, and upon conviction thereof, shall be punishable by a fine not to exceed twenty-five dollars (\$25.00) for the first violation; seventy-five dollars (\$75.00) for the second violation; and one hundred twenty-five dollars (\$125.00) for the third violation.

D.

Unless otherwise specified, each day that a prohibited condition exists shall constitute a separate offense.

(Ordinance 07-02 adopted 2007)

§ 15.28.090 Severability.

The provisions of this chapter are severable and if any paragraph, section, subsection, or part of this chapter is

held to be invalid, unenforceable, unconstitutional, or inapplicable to any person or circumstance, such illegality, invalidity, unconstitutionality, or inapplicability shall not affect or impair the remainder of this chapter.

(Ordinance 07-02 adopted 2007)

§ 15.28.100 **Effective date.**

The provisions of this chapter shall become effective five (5) days after published unless otherwise provided by law.

(Ordinance 07-02 adopted 2007)

§ 15.28.110 **Tables and figures.**

The following schematics show what is acceptable and what is unacceptable in the town:

A.

Figure 1, Wall Mounted Lights.

UNACCEPTABLE

ACCEPTABLE



WRAP AROUND
LENSES

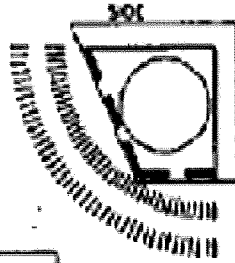

FRONT

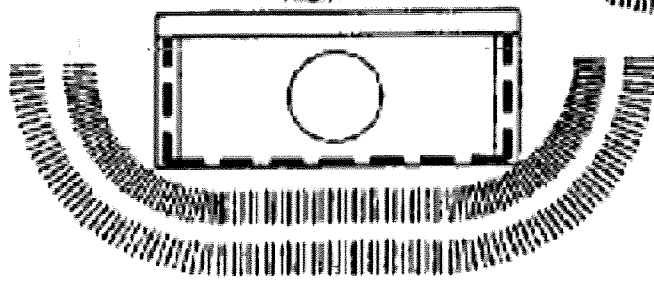

FRONT

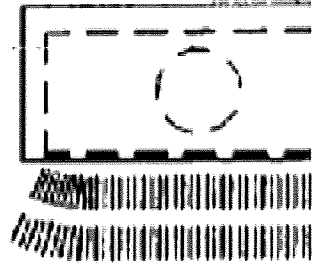

OPEN
FITURES

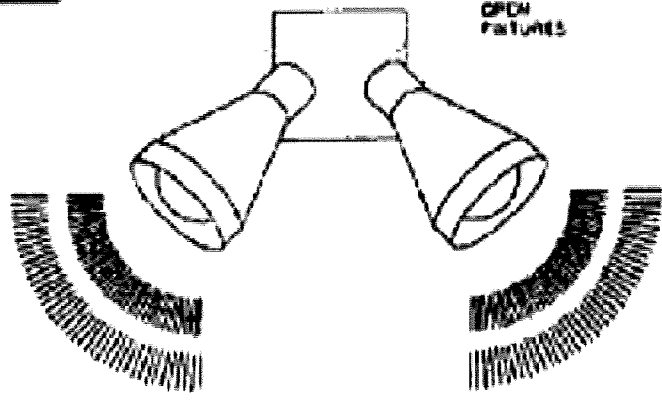

FRONT

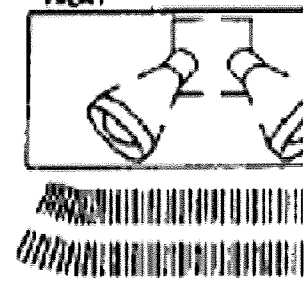

CAPSED
BULBS

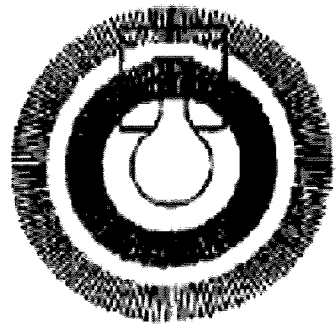

B.

Figure 2, Freestanding Lights.

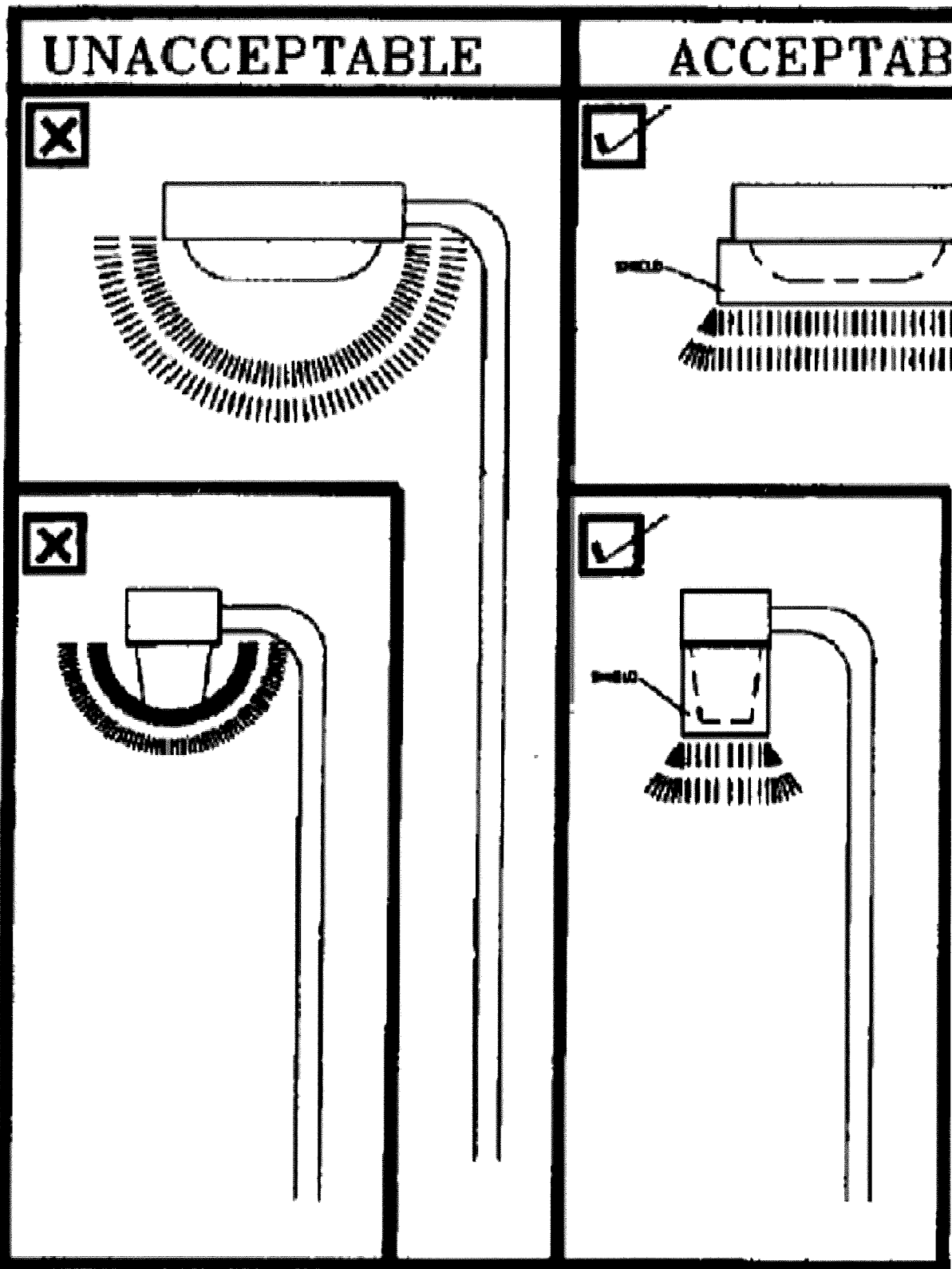

Street and Parking Lot Pole I

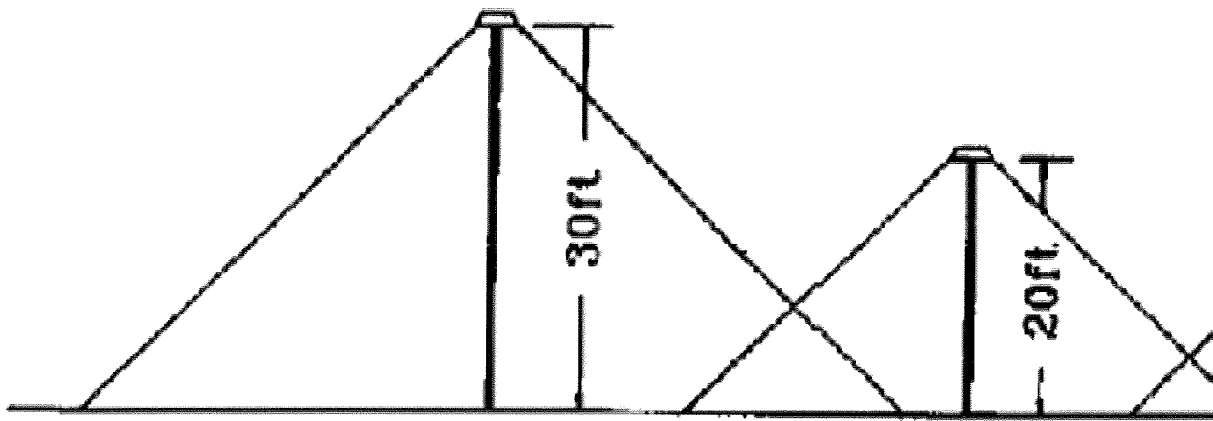

C.

Figure 3, Wall, Building, Foliage, Sign and Escarpment Lights.

UNACCEPTABLE

ACCEPT

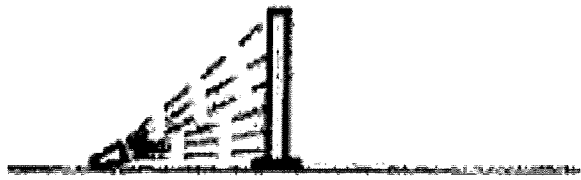

WALL

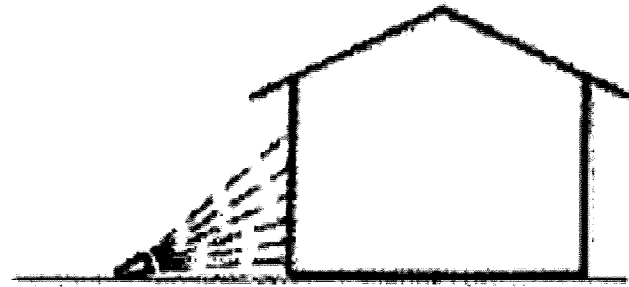
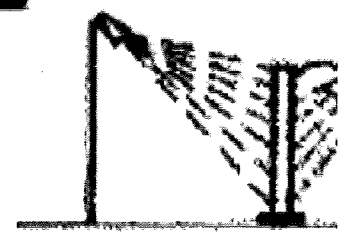

BUILDING

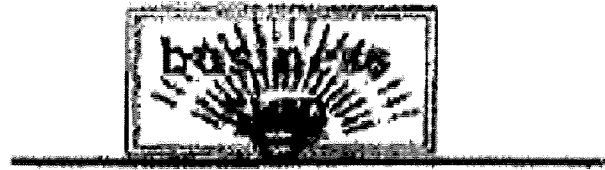

SIGN

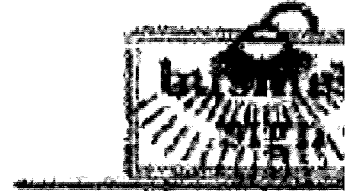

FOLIAGE

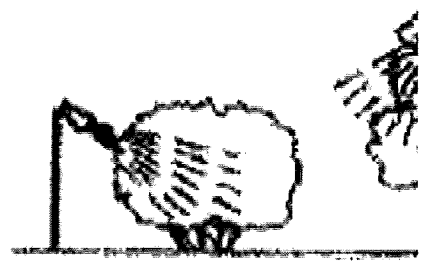

D.

Figure 4, Street and Lot Light Cutoff at Property Line.

UNACCEPTABLE

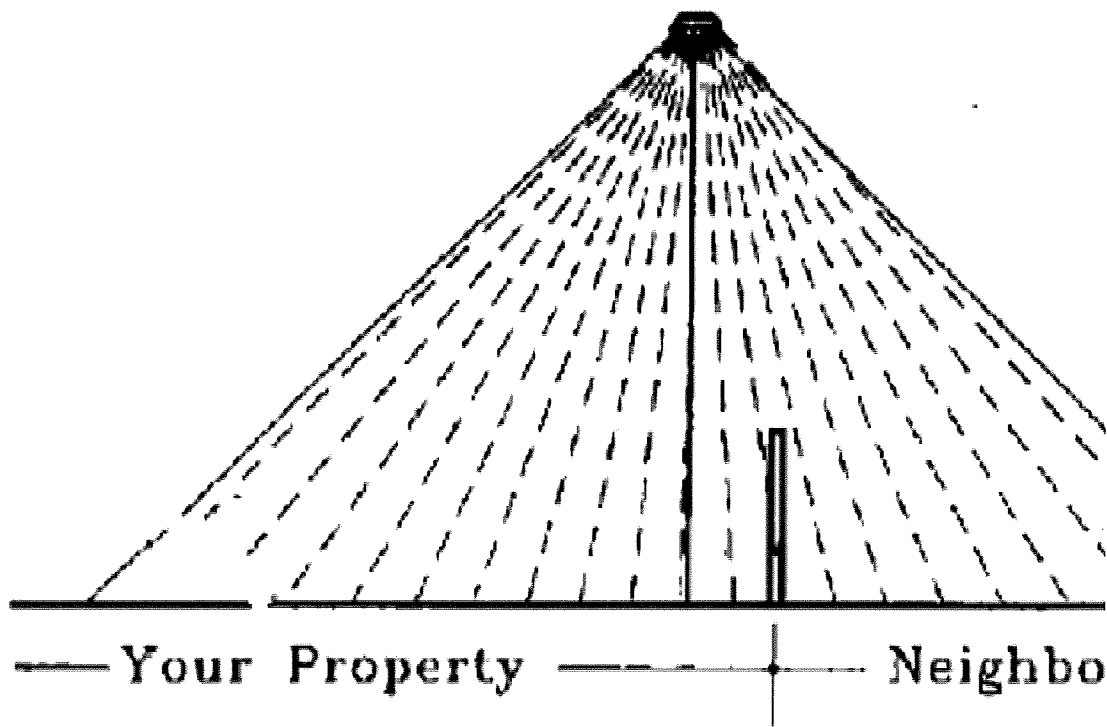

ACCEPTABLE

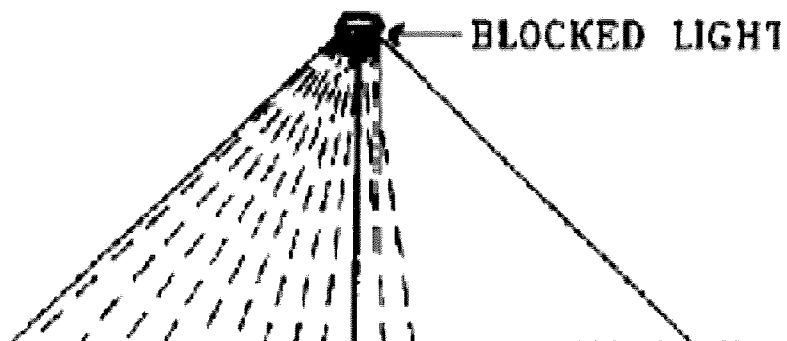

E.

Table 5, Light Type Wattage Comparisons.

For use in building wall pack and porch light fixtures.

Bulbs Lawful Outdoors in Town of Taos	Wattage of Bulb Allowed (with 2200+ Lumens Limit for Residential and Commercial Lights)¹
Incandescent	150 watts
High pressure sodium	35 watts
Low pressure sodium	18 watts
Metal halide (MID)	39 watts
Halogen	100 watts
Quartz	100 watts
Fluorescent	30 watts
Bulbs Unlawful in State of New Mexico	
Mercury vapor ²	75 watts

Notes:

1. Agricultural and government lights are limited to 50,000 lumens.
2. Grandfathered in New Mexico until the bulb/luminaire must be replaced. See State of New Mexico, 44th Legislature, 1st Session, Laws 1999, chapter 197, House Bill 39, as amended, signed April 6, 1999.

(Ordinance 07-02 adopted 2007)

By using eCode360 you agree to be legally bound by the [Terms of Use](#) and [Privacy Policy](#).